

Keysight Noise Figure Measurement Capability Upgrade Kit

To Upgrade PNA-X N5241A Option 219 or Option 224, N5242A Option 219 or Option 224, N5249A Option 219 or Option 224, N5241A-H85, N5242A-H85, or N5249A-H85 to include Option 029

Upgrade Kit Order Number: N5241AU-924, N5242AU-924, and N5249AU-924

Keysight Kit Number: N5242-60105

Notices

© Keysight Technologies, Inc.
2007-2016

No part of this manual may be reproduced in any form or by any means (including electronic storage and retrieval or translation into a foreign language) without prior agreement and written consent from Keysight Technologies, Inc. as governed by United States and international copyright laws.

Trademark Acknowledgments

Manual Part Number

N5242-90009

Edition

Edition 1, July 2016

Printed in USA/Malaysia

Published by:
Keysight Technologies
1400 Fountaingrove Parkway
Santa Rosa, CA 95403

Warranty

THE MATERIAL CONTAINED IN THIS DOCUMENT IS PROVIDED "AS IS," AND IS SUBJECT TO BEING CHANGED, WITHOUT NOTICE, IN FUTURE EDITIONS. FURTHER, TO THE MAXIMUM EXTENT PERMITTED BY APPLICABLE LAW, KEYSIGHT DISCLAIMS ALL WARRANTIES, EITHER EXPRESS OR IMPLIED WITH REGARD TO THIS MANUAL AND ANY INFORMATION CONTAINED HEREIN, INCLUDING BUT NOT LIMITED TO THE IMPLIED WARRANTIES OF MERCHANTABILITY AND FITNESS FOR A PARTICULAR PURPOSE. KEYSIGHT SHALL NOT BE LIABLE FOR ERRORS OR FOR INCIDENTAL OR CONSEQUENTIAL DAMAGES IN CONNECTION WITH THE FURNISHING, USE, OR PERFORMANCE OF THIS DOCUMENT OR ANY INFORMATION CONTAINED HEREIN. SHOULD KEYSIGHT AND THE USER HAVE A SEPARATE WRITTEN AGREEMENT WITH WARRANTY TERMS COVERING THE MATERIAL IN THIS

DOCUMENT THAT CONFLICT WITH THESE TERMS, THE WARRANTY TERMS IN THE SEPARATE AGREEMENT WILL CONTROL.

Technology Licenses

The hardware and/or software described in this document are furnished under a license and may be used or copied only in accordance with the terms of such license.

U.S. Government Rights

The Software is "commercial computer software," as defined by Federal Acquisition Regulation ("FAR") 2.101. Pursuant to FAR 12.212 and 27.405-3 and Department of Defense FAR Supplement ("DFARS") 227.7202, the U.S. government acquires commercial computer software under the same terms by which the software is customarily provided to the public.

Accordingly, Keysight provides the Software to U.S. government customers under its standard commercial license, which is embodied in its End User License Agreement (EULA), a copy of which can be found at

<http://www.keysight.com/find/sweula>

The license set forth in the EULA represents the exclusive authority by which the U.S. government may use, modify, distribute, or disclose the Software. The EULA and the license set forth therein, does not require or permit, among other things, that Keysight: (1) Furnish technical information related to commercial computer software or commercial computer software documentation that is not customarily provided to the public; or (2) Relinquish to, or otherwise provide, the government rights in excess of these rights customarily provided to the public to use, modify, reproduce, release, perform, display, or disclose commercial computer software or commercial computer software documentation. No additional

government requirements beyond those set forth in the EULA shall apply, except to the extent that those terms, rights, or licenses are explicitly required from all providers of commercial computer software pursuant to the FAR and the DFARS and are set forth specifically in writing elsewhere in the EULA. Keysight shall be under no obligation to update, revise or otherwise modify the Software. With respect to any technical data as defined by FAR 2.101, pursuant to FAR 12.211 and 27.404.2 and DFARS 227.7102, the U.S. government acquires no greater than Limited Rights as defined in FAR 27.401 or DFAR 227.7103-5 (c), as applicable in any technical data.

Safety Notices

CAUTION

A **CAUTION** notice denotes a hazard. It calls attention to an operating procedure, practice, or the like that, if not correctly performed or adhered to, could result in damage to the product or loss of important data. Do not proceed beyond a CAUTION notice until the indicated conditions are fully understood and met.

WARNING

A **WARNING** notice denotes a hazard. It calls attention to an operating procedure, practice, or the like that, if not correctly performed or adhered to, could result in personal injury or death. Do not proceed beyond a WARNING notice until the indicated conditions are fully understood and met.

Description of the Upgrade

NOTE

In June 2013, the N5241A/AS and N5242A/AS analyzers underwent significant hardware changes. Some components that have 2.4 mm connectors (bias tees, couplers, and some semi-rigid cables) were replaced with components that have 3.5 mm connectors.

If your analyzer's serial number prefix is MY/SG/US5310 and below:

Your analyzer was originally shipped with 2.4 mm components. Bias tees with 2.4 mm connectors are no longer available, so the bias tees and connecting cables included in this kit have 3.5 mm connectors. Since they are interconnected, the 2.4 mm couplers and connecting cables in your analyzer must be replaced with the new 3.5 mm items included in this kit.

If your analyzer's serial number prefix is MY/SG/US5321 and above:

Your analyzer was shipped with 3.5 mm components, so it is not necessary to replace the bias tees, couplers, and connecting cables. These items are included in this kit, but will not be used for your upgrade. Set them aside for possible use in the future.

Be very careful to use the appropriate hardware in your analyzer. Using the wrong hardware can ruin analyzer components, resulting in additional customer costs.

NOTE

For the N5241A/42A/49A, new instruments with Option 029 use a N5245-60124 noise receiver board. The N5245-60124 board requires the Windows 7 operating system and firmware A.10.47 or greater. This kit contains the older N5242-60098 noise receiver board, which works with all operating systems and firmware. This board is retained for customers that require backwards compatibility in their instruments.

This upgrade adds noise figure measurement capability to your Option 219 or Option 224 2-port analyzer by adding Option 029 which includes:

- a noise down converter and noise receiver
- a splitter to provide a signal to the noise down converter/receiver
- a bypass switch to each source port channel

Getting Assistance from Keysight

Installing this upgrade kit requires special skills and experience. If you think you may not be qualified to do the work, or need advice, contact Keysight.

Contacting Keysight

Assistance with test and measurements needs and information on finding a local Keysight office are available on the Web at:

<http://www.keysight.com/find/assist>

If you do not have access to the Internet, please contact your Keysight field engineer.

NOTE

In any correspondence or telephone conversation, refer to the Keysight product by its model number and full serial number. With this information, the Keysight representative can determine whether your product is still within its warranty period.

If You Have Problems With the Upgrade Kit Contents

Keysight stands behind the quality of the upgrade kit contents. If you have problems with any item in the kit, email Keysight Component Test Division (CTD) Support at support_ctd-soco@keysight.com, or telephone the CTD Hotline at (707) 577-6802 and leave a voice mail message. Please include details of the problem.

Getting Prepared

CAUTION

The PNA contains extremely sensitive components that can be ruined if mishandled. Follow instructions carefully when making cable connections, especially wire harness connections.

The person performing the work accepts responsibility for the full cost of the repair or replacement of damaged components.

To successfully install this upgrade kit, you will need the following:

- A license key - refer to **“License Key Redemption”** below.
- A PDF copy or a paper copy of the PNA Service Guide - refer to **“Downloading the Online PNA Service Guide”** below.
- An ESD-safe work area - refer to **“Protecting Your Workspace from Electrostatic Discharge”** below.
- Correct tools - refer to **“Tools Required for the Installation” on page 7.**
- Enough time - refer to **“About Installing the Upgrade” on page 7.**
- Test equipment for the post-upgrade adjustments and full instrument calibration. To view the equipment list, click the Chapter 3 bookmark “Tests and Adjustments” in the PDF Service Guide¹.

License Key Redemption

NOTE

The enclosed Option Entitlement Certificate is a receipt, verifying that you have purchased a licensed option for the PNA of your choice. You must now use a Keysight Web page to request a license key for the instrument that will receive the option.

To enable the option product, you must request a license key from: <http://www.keysight.com/find/softwarelicense>. To complete the request, you will need to gather the following information:

- From the certificate
 - Order number
 - Certificate number
- From your instrument
 - Model number
 - Serial number
 - Host ID

1. See **“Downloading the Online PNA Service Guide” on page 6.**

Getting Prepared

The instrument information is available on the network analyzer – on the analyzer’s Help menu, click About Network Analyzer.

If you provide an email address, Keysight will promptly email your license key. Otherwise, you will receive your license key via postal mail.

Downloading the Online PNA Service Guide

To view the online Service Guide for your PNA model number, use the following steps:

1. Go to www.keysight.com.
2. In the Search box, enter the model number of the analyzer (Ex: N5242A) and click **Search**.
3. Click **Technical Support > Manuals**.
4. Click **Service Manual**.
5. Click the service guide title to download the PDF file.
6. When the PDF of the Service Guide is displayed, scroll through the Contents section bookmarks to locate the information needed.

Protecting Your Workspace from Electrostatic Discharge

For information, click on the Chapter 1 bookmark, “Electrostatic Discharge Protection” in the PDF Service Guide¹.

ESD Equipment Required for the Installation

Description	Keysight Part Number
ESD grounding wrist strap	9300-1367
5-ft grounding cord for wrist strap	9300-0980
2 x 4 ft conductive table mat and 15-ft grounding wire	9300-0797
ESD heel strap (for use with conductive floors)	9300-1308

Tools Required for the Installation

Description	Qty	Part Number
T-10 TORX driver (set to 9 in-lbs)	1	N/A
T-20 TORX driver (set to 21 in-lbs)	1	N/A
5/16-in torque wrench (set to 10 in-lbs)	1	N/A
5/16-in torque wrench (set to 21 in-lbs)	1	N/A
1-in torque wrench (set to 72 in-lbs)	1	N/A

CAUTION

Use a 5/16-in torque wrench set to 10 in-lbs on all cable connections except the front and rear panel bulkhead connectors. Torque these connections to 21 in-lb.

About Installing the Upgrade

Products affected	N5241A, N5242A, and N5249A Option 219 or 224 and N5241A-H85, N5242A-H85 and N5249A-H85
Installation to be performed by	Keysight service center or personnel qualified by Keysight
Estimated installation time	5 hours
Estimated adjustment time	0.5 hours
Estimated full instrument calibration time	4.5 hours

Items Included in the Upgrade Kit

Check the contents of your kit against the following list. If any part is missing or damaged, contact Keysight Technologies. Refer to **“Getting Assistance from Keysight” on page 4.**

Table 1 Contents of Upgrade Kit N5242-60105

Ref Desig.	Description	Qty	Part Number
-	Installation note (this document)	1	N5242-90009
-	Entitlement certificate	1	5964-5145
Accessory Items			
Note to Installer The following two items are used when performing vector-corrected noise figure measurements and are not used in the upgrade. They are packaged separately in the kit and must remain with the analyzer.			
	Female-to-female adapter used to connect an ECal module	1	85052-60013
	RF cable used to connect an ECal module	1	N5242-20137
Assemblies			
A7	Noise receiver board	1	N5242-60098
A16	Power supply	1	0950-4934
A22	Splitter	1	5087-7139
A29, A32	Test port couplers	2	5087-7813
A38, A41	Bias tee (includes wire harness)	2	5067-4865
A52	Bypass switch, port 1	1	N1811-60030 Was N1811-60008
A53	Bypass switch, port 2	1	N1811-60028
A54	Bridge	1	5087-7794
A55	Noise downconverter	1	5087-7767
Hardware/Miscellaneous			
	Switch/attenuator bracket	2	N5242-00031
	Bias tee bracket	2	N5242-00032
	Machine screw, M3.0 x 18, pan head (to attach A52 and A53 to switch brackets and to attach A22 to mixer brick block)	6	0515-0666
	Machine screw, M3.0 x 6, pan head (to attach bias tee brackets)	4	0515-0430

Items Included in the Upgrade Kit

Table 1 Contents of Upgrade Kit N5242-60105

Ref Desig.	Description	Qty	Part Number
	Machine screw, M3.0 x 20, pan head (to attach A54 to side frame)	1	0515-1410
	Hex nut with lock washer (for screw 0515-1410; to attach A54 to side frame)	1	0535-0031
	Machine screw, M3.0 x 10, pan head (to attach A55 to side frame)	3	0515-0374
	Gap pad for test port coupler	2	E4403-20033
	Vibe mount for test port coupler	2	0460-2725
	Bumper for test port coupler	2	0403-0285
	Lower front panel overlay (Option 219/029)	1	N5242-80010
	Lower front panel overlay (Option 224/029)	1	N5242-80011
	Lower front panel overlay (Option H85/219/029)	1	N5242-80017
	Lower front panel overlay (Option H85/224/029)	1	N5242-80018
	Bulkhead connector assembly for test set front plate	11	1250-3805
Cables			
W42	RF cable, A21 HMA26.5 to A22 splitter	1	N5222-20009
W43	RF cable, A22 splitter to A23 mixer brick	1	N5222-20007
W85	RF cable, front-panel Port 2 CPLR THRU to A41 port 2 bias tee	1	N5222-20035
W115	RF cable, front-panel Port 1 CPLR ARM to A29 port 1 coupler (N5241/42A-H85 only)	1	N5222-20070
W116	RF cable, A32 port 2 coupler to front-panel Port 2 CPLR THRU (N5241/42A-H85 only)	1	N5222-20069
W117	RF cable, A32 port 2 coupler to front-panel Port 2 CPLR ARM	1	N5222-20071
W119	RF cable, A38 port 1 bias tee to A29 port 1 coupler	1	N5222-20072
W120	RF cable, A41 port 2 bias tee to A32 port 2 coupler	1	N5222-20065
W121	RF cable, A25 port 1 bridge to A34 port 1 source attenuator	1	N5242-20273
W122	RF cable, A34 port 1 source attenuator to A52 port 1 bypass switch	1	N5242-20298
W123	RF cable, A52 port 1 bypass switch to front-panel Port 1 SOURCE OUT	1	N5242-20297
W124	RF cable, front-panel Port 1 CPLR THRU to A52 port 1 bypass switch	1	N5242-20295
W125	RF cable, A52 port 1 bypass switch to A38 port 1 bias tee	1	N5242-20296
W126	RF cable, A28 port 2 bridge to A37 port 2 source attenuator	1	N5242-20272
W127	RF cable, A37 port 2 source attenuator to A53 port 2 bypass switch	1	N5242-20292
W128	RF cable, A53 port 2 bypass switch to front-panel Port 2 SOURCE OUT	1	N5242-20303
W129	RF cable, A53 port 2 bypass switch to A54 port 2 bridge	1	N5242-20293
W130	RF cable, A52 port 2 bypass switch to A54 port 2 bridge	1	N5242-20302
W131	RF cable (male-to-male adapter), A54 port 2 bridge to A55 noise down converter	1	1250-3576
W132	RF cable, front-panel Port 1 RCVR A IN to A42 port 1 receiver attenuator	1	N5242-20277
W133	RF cable, A42 port 1 receiver attenuator to A23 mixer brick (A)	1	N5242-20275
W134	RF cable, A45 port 2 receiver attenuator to A23 mixer brick (B)	1	N5242-20276
W135	RF cable, front-panel Port 2 RCVR B IN to A45 port 2 receiver attenuator	1	N5242-20278

Items Included in the Upgrade Kit

Table 1 Contents of Upgrade Kit N5242-60105

Ref Desig.	Description	Qty	Part Number
W136	RF cable, A33 reference mixer switch to A23 mixer brick (R1)	1	N5242-20274
W137	RF cable, A28 port 2 bridge to front-panel REF 2 SOURCE OUT	1	N5242-20279
W138	RF cable, front-panel REF 2 RCVR R2 IN to A23 mixer brick (R2)	1	N5242-20280
W139	RF cable, A22 splitter to A55 noise downconverter	1	N5242-20301
W141	RF cable, A55 noise downconverter to A7 noise receiver board LO	1	N5242-20299
W142	RF cable, A55 noise downconverter J4 to A7 noise receiver board P2	1	N5242-60041
W143	RF cable, A55 noise downconverter to A7 noise receiver board RF	1	N5242-20300
W145	RF cable, A52 port 1 bypass switch to A29 port 1 coupler (N5241/42A-H85 only)	1	N5242-20305
	Ribbon cable, A19 test set motherboard J548 to A55 noise downconverter J1	1	N5242-60033

NOTE

Extra quantities of items such as protective plastic caps, screws, cable ties, and cable clamps may be included in this upgrade kit. It is normal for some of these items to remain unused after the upgrade is completed.

Installation Procedure for the Upgrade

The network analyzer must be in proper working condition prior to installing this option. Any necessary repairs must be made before proceeding with this installation.

WARNING

This installation requires the removal of the analyzer's protective outer covers. The analyzer must be powered down and disconnected from the mains supply before performing this procedure.

Overview of the Installation Procedure

- “Step 1. Obtain a Keyword and Verify the Information.”
- “Step 2. Remove the Outer Cover.”
- “Step 3. Remove the Inner Cover.”
- “Step 4. Remove the Front Panel Assembly.”
- “Step 5. Remove Some Existing Test Set Cables.”
- “Step 6. Remove the Existing Attenuators, Brackets, and Bias Tees (If Present).”
- “Step 7. Assemble the Old Attenuators and the New A52 and A53 Bypass Switches onto the New Brackets.”
- “Step 8. Install the New Brackets, with the Old Attenuators and the New A52 and A53 Bypass Switches, and 3.5 mm Bias Tees (If Present) into the Analyzer.”
- “Step 9. Assemble the A29 and A32 Test Port Coupler Assemblies (For Analyzers with Serial Numbers Prefixed MY/SG/US5310 and Below).”
- “Step 10. Install the New (3.5 mm) A29 and A32 Test Port Couplers onto the Front Plate (For Analyzers with Serial Numbers Prefixed MY/SG/US5310 and Below).”
- “Step 11. Assemble and Install the A54 Bridge and A55 Noise Downconverter.”
- “Step 12. Install the A22 Splitter.”
- “Step 13. Install the A7 Noise Receiver Board.”
- “Step 14. Install the Bulkhead Connectors in the Test Set Front Plate (For All Analyzers with Serial Numbers Prefixed MY/SG/US5310 and Below).”
- “Step 15. Install the Test Set Cables.”
- “Step 16. Replace the A16 Power Supply (If Necessary).”
- “Step 17. Replace the Lower Front Panel Overlay.”
- “Step 18. Reinstall the Front Panel Assembly and Front Panel Jumpers.”

“Step 19. Position the Cables and Wires to Prevent Pinching.”

“Step 20. Reinstall the Inner Cover.”

“Step 21. Reinstall the Outer Cover.”

“Step 22. Enable Option 029.”

“Step 23. Verify Option 028 is Not Installed.”

“Step 24. Perform Post-Upgrade Adjustments and Calibration.”

“Step 25. Prepare the PNA for the User.”

Step 1. Obtain a Keyword and Verify the Information

Follow the instructions on the Option Entitlement Certificate supplied to obtain a license key for installation of this upgrade. Refer to “[License Key Redemption](#)” on page 5.

Verify that the model number, serial number, and option number information on the license key match those of the instrument on which this upgrade will be installed.

If the model number, serial number, or option number do not match those on your license key, you will not be able to install the option. If this is the case, contact Keysight for assistance before beginning the installation of this upgrade. Refer to “[Contacting Keysight](#)” on page 4.

Once the license key has been received and the information verified, you can proceed with the installation at step 2.

Step 2. Remove the Outer Cover

CAUTION

This procedure is best performed with the analyzer resting on its front handles in the vertical position. *Do not place the analyzer on its front panel without the handles.* This will damage the front panel assemblies.

Refer to [Figure 1](#) for this step of the procedure.

1. Disconnect the power cord (if it has not already been disconnected).
2. Remove the strap handles (item \neg) by loosening the screws (item \hat{A}), with a T-20 TORX driver, on both ends until the handle is free of the analyzer.
3. Remove the foot locks (item \textcircled{R}) from the four bottom feet (item \neg) and then remove the four bottom feet from the outer cover.
4. Remove the four rear panel feet (item \circ) by removing the center screws (item \pm) with a T-20 TORX driver.
5. Slide the outer cover toward the rear of the analyzer and remove it.

Figure 1 Outer Cover Removal

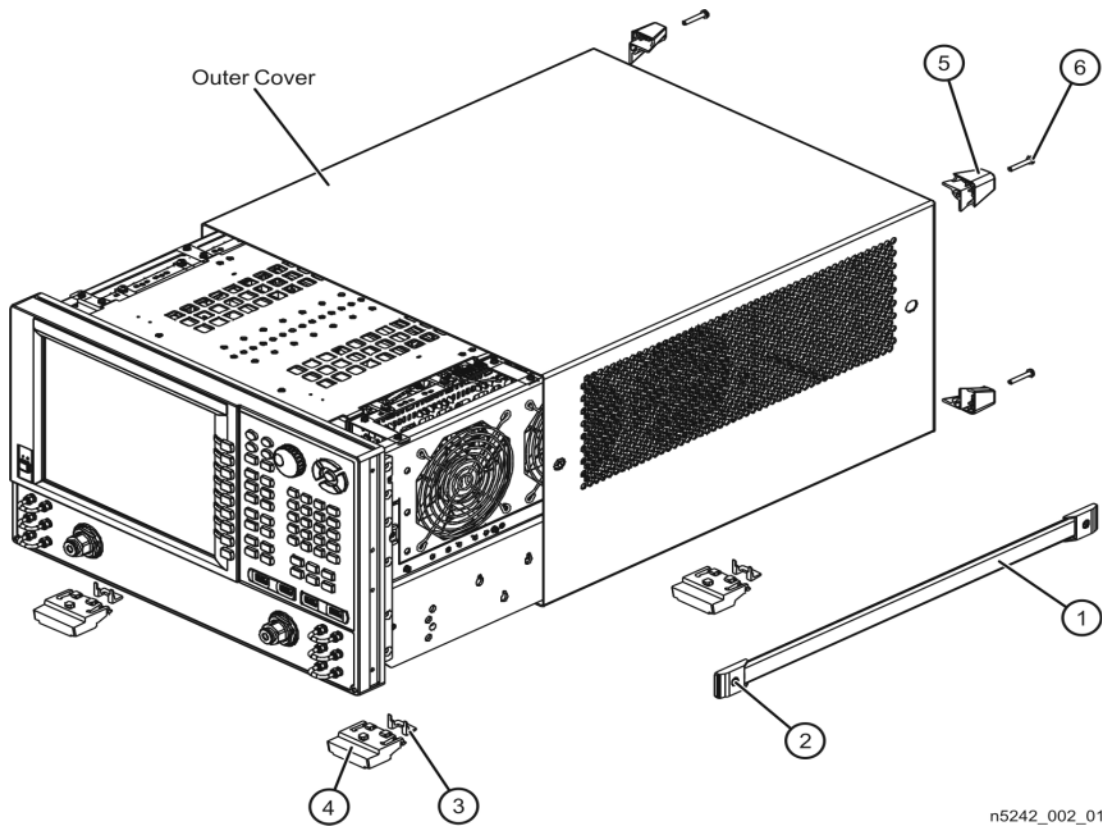

Step 3. Remove the Inner Cover

Refer to **Figure 2** for this step of procedure.

1. With a T-10 TORX driver, remove the 12 pan head screws (item \neg).
2. With a T-10 TORX driver, remove the 9 flat head screws (item \hat{A}).
3. Lift off the cover.

Figure 2 Inner Cover Removal

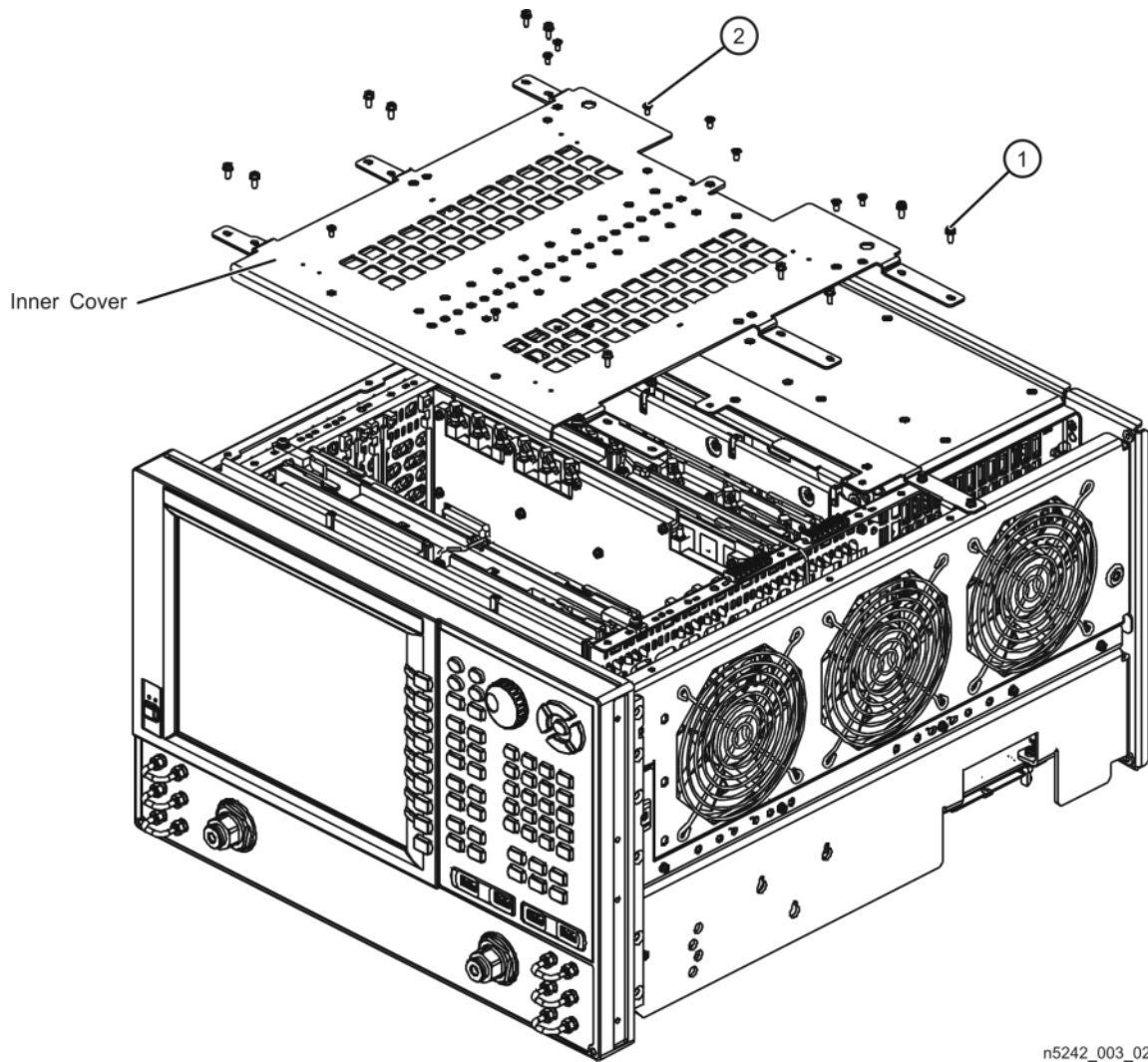

n5242_003_02

Step 4. Remove the Front Panel Assembly

Refer to **Figure 3** for this step of procedure.

1. With a 5/16-in wrench, remove all front panel jumpers (item \neg).
2. With a T-10 TORX driver, remove the screws (item \hat{A}) from the sides of the frame.

CAUTION

Before removing the front panel from the analyzer, lift and support the front of the analyzer chassis.

3. Slide the front panel over the test port connectors.

4. Disconnect the front panel interface ribbon cable (item ⑧). The front panel is now free from the analyzer.

Figure 3 Front panel Assembly Removal

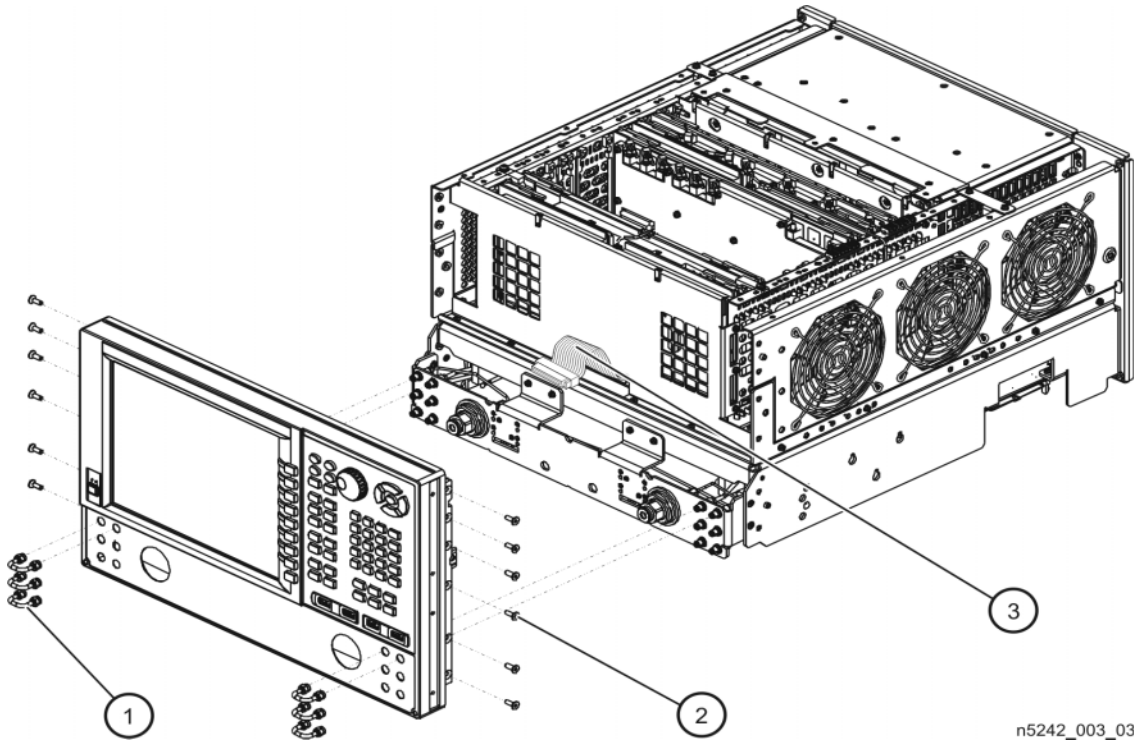

Step 5. Remove Some Existing Test Set Cables

NOTE

Leave the gray flexible cables, the wire harnesses, and the ribbon cables connected where possible. **Any that are removed should be labeled for reconnection later.**

CAUTION

Be careful not to damage the center pins of the semirigid cables. Some flexing of the cables may be necessary but do not over-bend them.

To see an image showing the location of these cables, click the appropriate Chapter 6 bookmark (Ex: “2-Port Configuration, Options 200/219/224/029”) in the PDF Service Guide.

1. Place the analyzer bottom-side up on a flat surface.
2. Remove the following cables in the order listed. Discard these cables; they will not be reused.

For all analyzer serial numbers

- W70 A21 HMA26.5 to A23 mixer brick

- W94 A45 port 2 receiver attenuator to A23 mixer brick (B)
- W71 A25 port 1 bridge to A34 port 1 source attenuator
- W88 A42 port 1 receiver attenuator to A23 mixer brick (A)
- W37 A33 reference mixer switch to A23 mixer brick (R1)
- W25 A28 port 2 bridge to front-panel REF 2 SOURCE OUT
- W83 A28 port 2 bridge to A37 port 2 source attenuator
- W72 A34 port 1 source attenuator to front-panel Port 1 SOURCE OUT
- W87 Front-panel Port 1 RCVR A IN to A42 port 2 receiver attenuator
- W93 Front-panel Port 2 RCVR B IN to A45 port 2 receiver attenuator
- W40 (W154 in Option 224 PNA) Front-panel REF 2 RCVR R2 IN to A23 mixer brick (R2)
- W84 A37 port 2 source attenuator to front-panel Port 2 SOURCE OUT

For analyzers with serial numbers prefixed MY/SG/US5310 and below:

- W115 Front-panel Port 1 CPLR ARM to A29 Port 1 coupler
- W117 Front-panel Port 2 CPLR ARM to A32 Port 2 coupler

If bias tee option is installed (NOT N5241/42A-H85):

For all analyzer serial numbers:

- W73 Front-panel Port 1 CPLR THRU to A38 port 1 bias tee

For analyzers with serial numbers prefixed MY/SG/US5310 and below:

- W119 A38 port 1 bias tee to A29 port 1 coupler
- W120 A41 port 2 bias tee to A32 port 2 coupler
- W85 Front-panel Port 2 CPLR THRU to A41 port 2 bias tee

If bias tee option is not installed (N5241/42A-H85):

For all analyzer serial numbers:

- W114 Front-panel Port 1 CPLR THRU to A29 Port 1 coupler

For analyzers with serial numbers prefixed MY/SG/US5310 and below:

- W116 A32 port 2 coupler to front-panel Port 2 CPLR THRU

3. Disconnect the ribbon cable from each of the step attenuator connectors. It is not necessary to disconnect these ribbon cables from the A19 test set motherboard; connector designations are given here for reference only.

- a. Item □ connects between the A42 port 1 receiver attenuator and A19 test set motherboard connector J205.

- b. Item \hat{A} connects between the A34 port 1 source attenuator and A19 test set motherboard connector J201.
- c. Item \hat{R} connects between the A45 port 2 receiver attenuator and A19 test set motherboard connector J208.
- d. Item $\bar{\quad}$ connects between the A37 port 2 source attenuator and A19 test set motherboard connector J204.

Step 6. Remove the Existing Attenuators, Brackets, and Bias Tees (If Present)

Refer to **Figure 4** for this step of the procedure. Although only Option 219 is shown in the illustration, Option 224 is similar in appearance. To see an image showing the precise location of all cables, click the appropriate Chapter 6 bookmark (Ex: “2-Port Configuration, Options 200/219/224/029”) in the PDF Service Guide.

1. Place the analyzer bottom-side up on a flat surface.

If bias tee option is installed (NOT N5241/42A-H85):

For analyzers with serial numbers prefixed MY/SG/US5321 and above:

Remove two screws (item $\bar{\quad}$) from the A38 port 1 bias tee and the A41 port 2 bias tee and lift them out of the PNA, and set them aside for reinstallation later.

For analyzers with serial numbers prefixed MY/SG/US5310 and below:

Remove two screws (item $\bar{\quad}$) from the A38 port 1 bias tee and the A41 port 2 bias tee and lift them out of the PNA. These old bias tees have 2.4 mm connectors and will be replaced later with bias tees having 3.5 mm connectors.

For all analyzers:

2. Remove three screws (item \hat{A}) from each attenuator bracket.
3. Remove the attenuator brackets, with the attenuators still attached, from the analyzer.
4. If it is necessary to remove any other cables from the analyzer to facilitate removal of the attenuators and bias tees brackets, be sure to note their locations and set them aside for reinstallation later.

Figure 4 Existing Attenuators and Brackets Removal

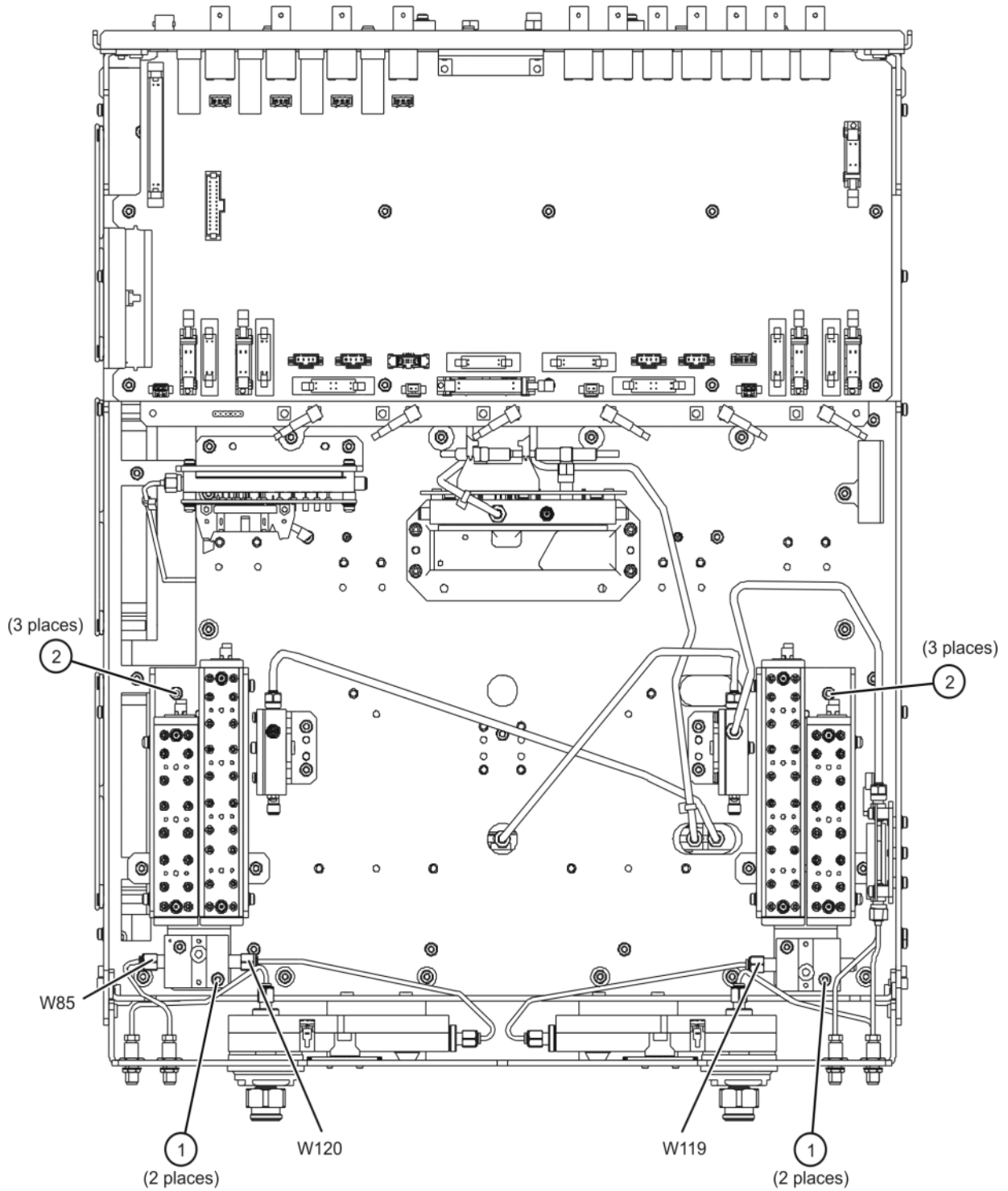

n5242_009_02

Step 7. Assemble the Old Attenuators and the New A52 and A53 Bypass Switches onto the New Brackets

Refer to **Figure 5** for this step of the procedure. New parts are listed in Table 1 on page 7.

1. Position each new bypass switch on a new switch bracket as shown. Make sure that the switches are oriented as shown; they are not oriented the same for both ports. The A52 switch, with the longest cable, is for port 1.
2. Secure each switch to its bracket using two screws (item \neg) for each.
3. Remove the source and receiver attenuators from the old bracket and, using the same screws (item \hat{A}), attach them to the new brackets. Make sure that they are oriented as shown; they are not oriented the same for both ports.
4. Secure the bias tee brackets to the attenuator brackets using two screws (item \textcircled{R}) for each.

Figure 5

Attenuators and Bypass Switches Assembly

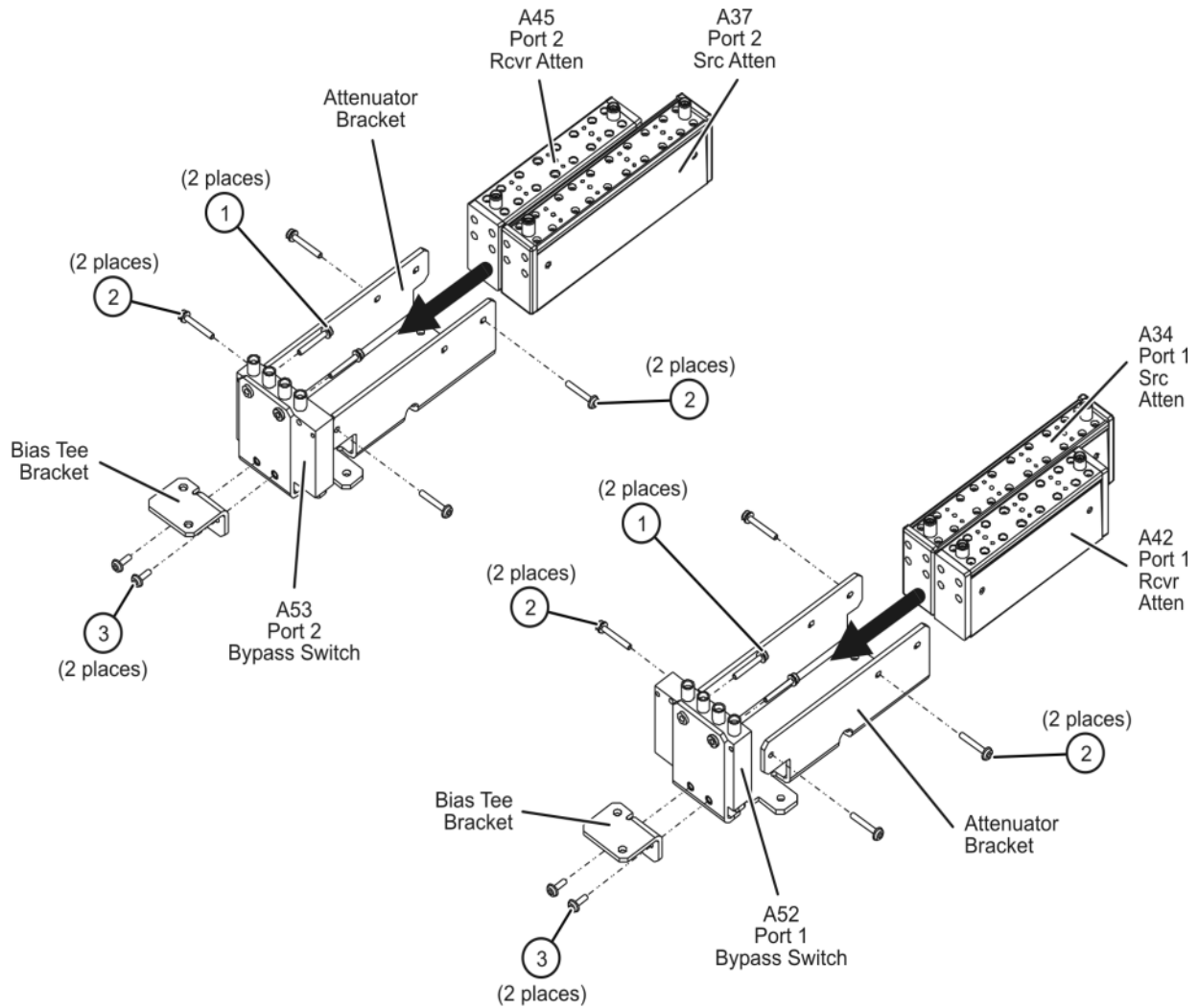

n5242_009_03

Step 8. Install the New Brackets, with the Old Attenuators and the New A52 and A53 Bypass Switches, and 3.5 mm Bias Tees (If Present) into the Analyzer

Refer to **Figure 6** for this step of the procedure. Although only Option 219 is shown in the illustration, Option 224 is similar in appearance. New parts are listed in **Table 1 on page 8**.

1. Position the attenuator brackets, with the attenuators and bypass switches attached, in the analyzer as shown. Make sure that the brackets are placed as shown; the attenuators and bypass switches are not oriented the same for both ports.
2. Secure the attenuator brackets to the analyzer test set deck using three screws (item \rightarrow) for each.

If bias tee option is installed (NOT N5241/42A-H85):

CAUTION

Installing these bias tees backwards will cause damage to the analyzer source modules.

For analyzers with serial numbers prefixed MY/SG/US5321 and above:

Position the existing bias tees, configured as shown in **Figure 6**, on the new bias tee brackets and secure each of them with the original two mounting screws (item \hat{A}).

For analyzers with serial numbers prefixed MY/SG/US5310 and below:

Position the new 3.5 mm bias tees, configured as shown in **Figure 6**, on the new bias tee brackets and secure each of them with the original two mounting screws (item \hat{A}).

For all analyzers:

3. Reinstall other cables that were removed to facilitate removal of the old attenuator brackets.

Figure 6 New Brackets Installation into the Analyzer

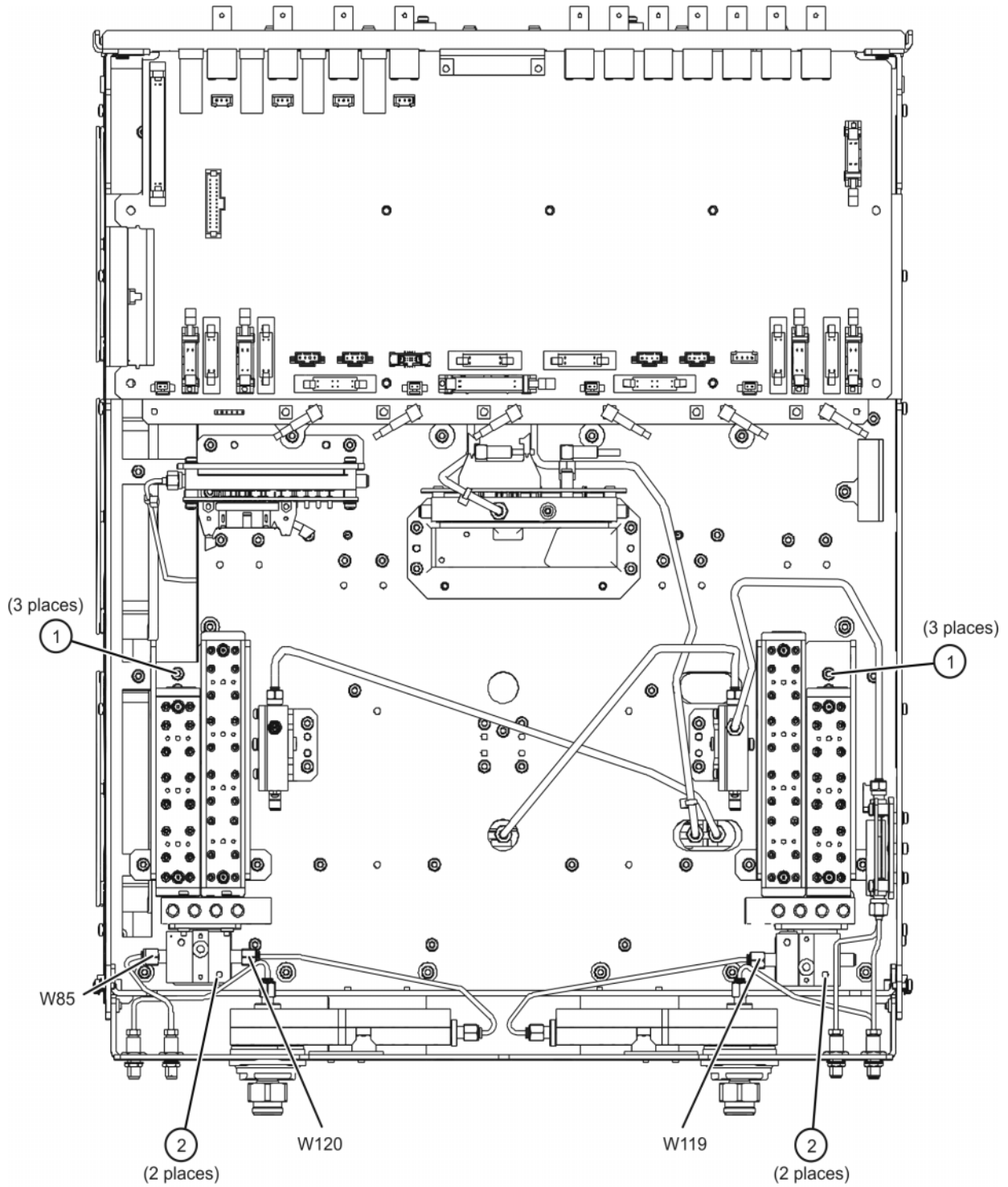

n5242_009_04

Step 9. Assemble the A29 and A32 Test Port Coupler Assemblies (For Analyzers with Serial Numbers Prefixed MY/SG/US5310 and Below)

1. Remove the A29 test port 1 coupler and A32 test port 2 coupler from the PNA. For instructions, click the Chapter 7 bookmark, “Removing and Replacing the A29 - A32 Test Port Couplers” in the PDF Service Guide.
2. Discard the test port couplers you just removed from the PNA. These old couplers have 2.4 mm connectors and must be replaced with the new couplers (3.5 mm connectors) included in the kit.
3. Follow the two instructions shown in **Figure 7**. New parts are listed in **Table 1 on page 8** of this document.

Figure 7 A29 and A32 Test Port Coupler Assembly

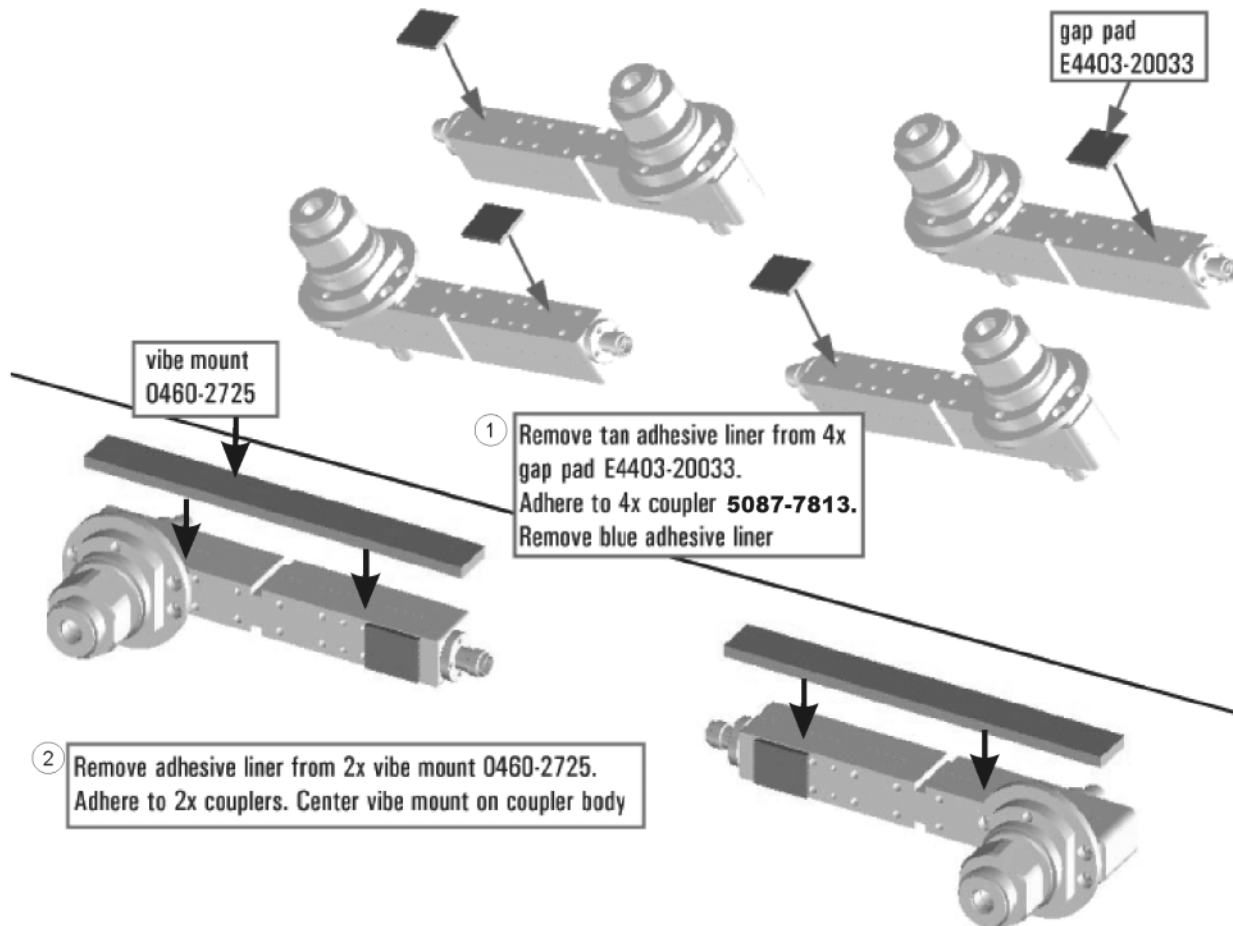

N5242_016_11

Step 10. Install the New (3.5 mm) A29 and A32 Test Port Couplers onto the Front Plate (For Analyzers with Serial Numbers Prefixed MY/SG/US5310 and Below)

1. Install the two new test port couplers onto the front plate.
2. Reinstall the two mounting nuts, but hand tighten only. Do not torque. They will be fully tightened later.

Step 11. Assemble and Install the A54 Bridge and A55 Noise Downconverter

Refer to **Figure 8** for this step of the procedure. New parts are listed in **Table 1 on page 8**.

1. Connect the A54 bridge to the A55 noise downconverter, using cable adapter W131, as shown. Place these assemblies on a flat surface and torque each W131 connector to 10 in-lbs while holding the A54 and A55 assemblies flat.
2. Connect the ribbon cable (item \curvearrowright) to the A55 noise downconverter connector as shown.
3. Place the combined A54/W131/A55 assembly into the analyzer as shown.
4. Secure the A55 noise downconverter to the side frame using three screws (item \hat{A}), as shown.
5. Secure the A54 bridge to the side frame using one screw (item \textcircled{R}) and one hex nut with lock washer (item $\bar{\quad}$), as shown. Install the screw from the outside of the side frame, through the top hole in the A54 bridge, and place the nut/washer on the inside. Hold the hex nut with a wrench while tightening the screw.

Figure 8

A54 Bridge and A55 Noise Down Converter Installation

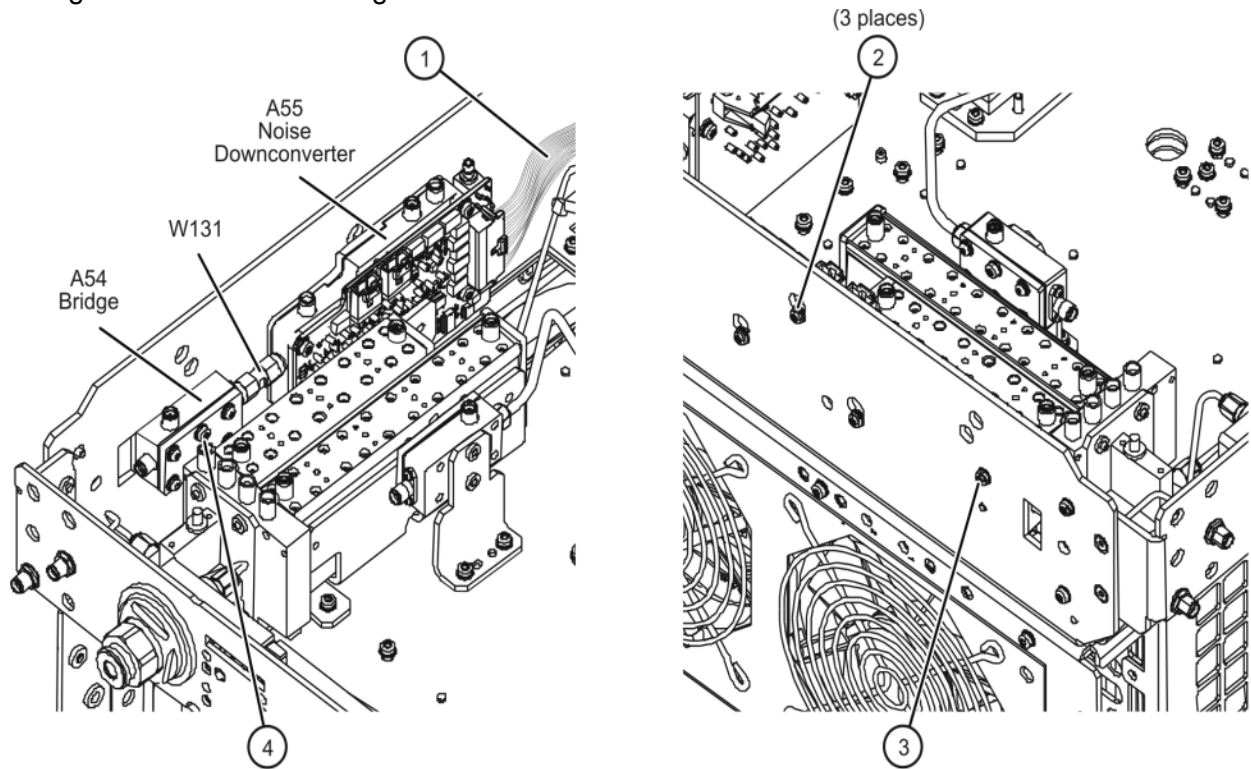

n5242_009_05

Step 12. Install the A22 Splitter

Refer to **Figure 9** for this step of the procedure. Although only Option 219 is shown in the illustration, Option 224 is similar in appearance. New parts are listed in **Table 1 on page 8**.

1. Position the A22 splitter on top of the mixer brick mounting block as shown.
2. Secure the A22 splitter with two screws (item \curvearrowright) as indicated.

Figure 9 A22 Splitter Installation

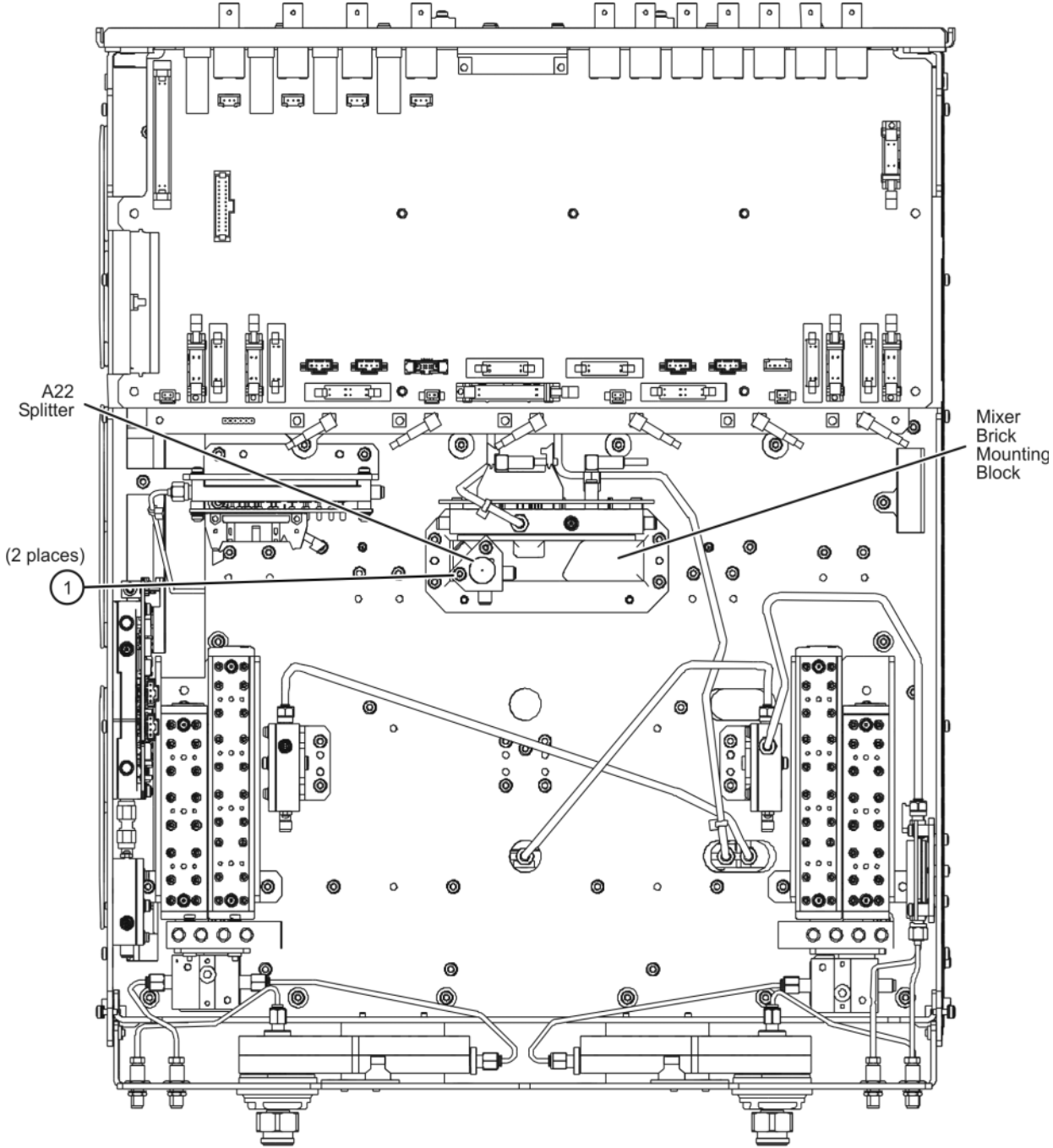

n5242_009_06

Step 13. Install the A7 Noise Receiver Board

Refer to **Figure 10** for this part of this step of the procedure. Although only Option 219 is shown in the illustration, Option 224 is similar in appearance. New parts are listed in **Table 1 on page 8**.

1. Place the analyzer top-side up on a flat surface.
2. Insert the A7 noise receiver board in the analyzer as shown. Make sure it is fully seated in the motherboard connector.

Figure 10 Noise Receiver Board Installation

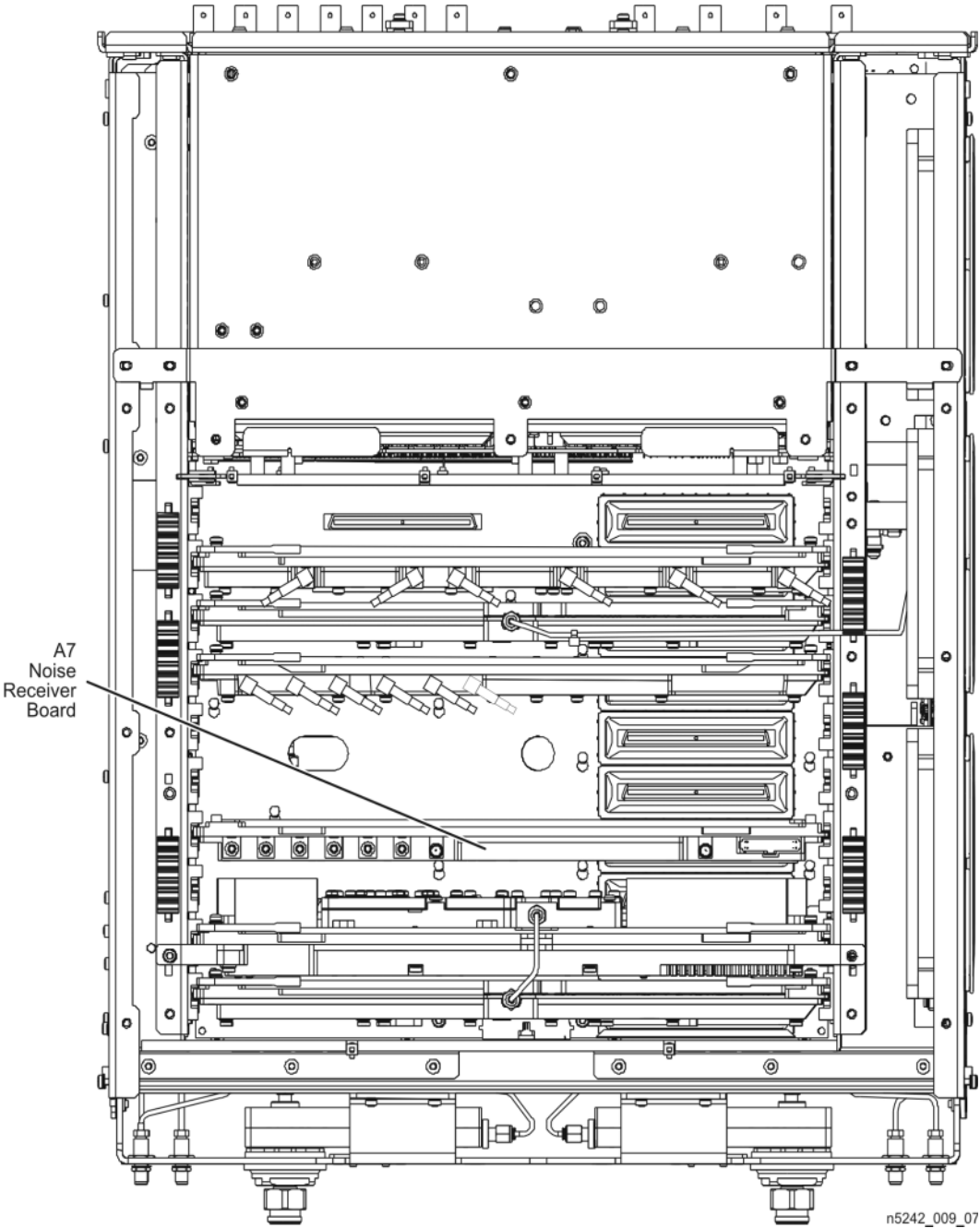

Step 14. Install the Bulkhead Connectors in the Test Set Front Plate
(For All Analyzers with Serial Numbers Prefixed MY/SG/US5310 and Below)

If your analyzer's serial number is MY/SG/US5321 and above, ignore this step.

Refer to **Figure 11** for this procedure. Some bulkhead connectors may already be installed on your analyzer's front plate. New parts are listed in **Table 1 on page 8**.

1. From the back side of the test set front plate, insert a bulkhead connector into a hole in the plate.
2. Install 1x washer and 1x nut. Hand tighten nut and ensure bulkhead connector hexagon nut, on the back side of test set front plate, is aligned to the test set subpanel hexagon indent.
3. Repeat previous two steps for the remaining bulkhead connectors.
4. Torque nuts, on the front side of test set front plate, to 21 in-lbs.
5. Torque mounting nuts for the test port couplers, on the front side of test set front plate, to 72 in-lbs.

Figure 11 Bulkhead Connectors Installation

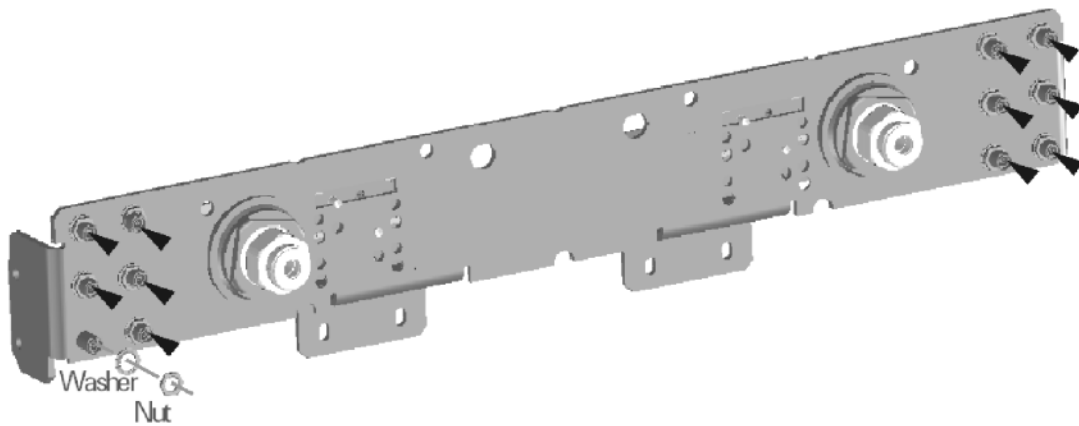

N5242_003_21

Step 15. Install the Test Set Cables

CAUTION

Follow instructions carefully when making cable connections, especially wire harness connections. Incorrect connections can destroy components, resulting in additional customer costs.

CAUTION

Be careful not to damage the center pins of the semirigid cables. Some flexing of the cables may be necessary but do not over-bend them.

CAUTION







Use a 5/16-in torque wrench set to 10 in-lbs on all cable connections except the front and rear panel bulkhead connectors. On these, use a 9 mm nutsetter or open end torque wrench set to 21 in-lb.

CAUTION

Some of these cables may have different dimensions from those shown in the graphics.

To see an image showing the location of these cables, click the appropriate Chapter 6 bookmark (Ex: "2-Port Configuration, Options 200/219/224/029") in the PDF Service Guide. New parts are listed in [Table 1 on page 8](#).

1. Connect the following wire harness and ribbon cables:

- —A42 port 1 receiver attenuator to A19 test set motherboard J205
- —A34 port 1 source attenuator to A19 test set motherboard J201
- —A45 port 2 receiver attenuator to A19 test set motherboard J208
- —A37 port 2 source attenuator to A19 test set motherboard J204
- —A53 port 2 bridge to A55 noise downconverter J11
- —A52 port 1 bridge to A55 noise downconverter J10
- —A55 noise downconverter J1 to A19 test set motherboard J548

2. Install the following semirigid cables in the order listed. Use a 5/16-in torque wrench set to 10 in-lbs to tighten all cable connectors.

For all analyzer serial numbers

- W135(N5242-20278) Front-panel Port 2 RCVR B IN to A45 port 2 receiver attenuator
- W129(N5242-20293) A53 port 2 bypass switch to A54 port 2 bridge
- W128(N5242-20303) A53 port 2 bypass switch to front-panel Port 2 SOURCE OUT
- W130(N5242-20302) A53 port 2 bypass switch to A54 port 2 bridge

Installation Procedure for the Upgrade

- W127(N5242-20292) A37 port 2 source attenuator to A53 port 2 bypass switch
- W132(N5242-20277) Front-panel Port 1 RCVR A IN to A42 port 1 receiver attenuator
- W124(N5242-20295) Front-panel Port 1 CPLR THRU to A52 port 1 bypass switch
- W122(N5242-20298) A34 port 1 source attenuator to A52 port 1 bypass switch
- W123(N5242-20297) A52 port 1 bypass switch to front-panel Port 1 SOURCE OUT
- W126(N5242-20272) A28 port 2 bridge to A37 port 2 source attenuator
- W137(N5242-20279) A28 port 2 bridge to front-panel REF 2 SOURCE OUT
- W136(N5242-20274) A33 reference mixer switch to A23 mixer brick (R1)
- W133(N5242-20275) A42 port 1 receiver attenuator to A23 mixer brick (A)
- W121(N5242-20273) A25 port 1 bridge to A34 port 1 source attenuator
- W139(N5242-20301) A22 splitter to A55 noise down converter
- W134(N5242-20276) A45 port 2 receiver attenuator to A23 mixer brick (B)
- W138(N5242-20280) Front-panel REF 2 RCVR R2 IN to A23 mixer brick (R2)
- W43(N5222-20007) A22 splitter to A23 mixer brick
- W42(N5222-20009) A21 HMA26.5 to A22 splitter

For analyzers with the bias tee option installed (NOT N5241/42A-H85):

All analyzer serial numbers:

- W125(N5242-20296) A52 port 1 bypass switch to A38 port 1 bias tee
- W85(N5222-20035) front-panel Port 2 CPLR THRU to A41 port 2 bias tee
- W119(N5222-20072) A38 port 1 bias tee to A29 port 1 coupler
- W120(N5222-20065) A41 port 2 bias tee to A32 port 2 coupler

Analyzer serial numbers prefixed MY/SG/US5310 and below:

- W117(N5222-20071) A32 port 2 coupler to front-panel Port 2 CPLR ARM
- W115(N5222-20070) Front-panel Port 1 CPLR ARM to A29 Port 1 coupler

For analyzers with the bias tee option not installed (N5241/42A-H85):

All analyzer serial numbers:

- W145(N5242-20305) A52 port 1 bypass switch to A29 port 1 coupler

Analyzer serial numbers prefixed MY/SG/US5310 and below:

- W115(N5222-20070) Front-panel Port 1 CPLR ARM to A29 Port 1 coupler
- W116(N5222-20069) Front-panel Port 2 CPLR THRU to A32 Port 2 coupler
- W117(N5222-20071) Front-panel Port 2 CPLR ARM to A32 Port 2 coupler

3. Position the analyzer as shown in **Figure 12 on page 33** (fans facing upwards) and loosely install the following cables. Route each of the cables through the opening in the test set deck to the top side of the analyzer. The other ends will be connected in the next step.

- W143(N5242-20300) Semirigid cable, A55 noise down converter to A7 noise receiver board RF
- W141(N5242-20299) Semirigid cable, A55 noise downconverter to A7 noise receiver board LO
- W142(N5242-60041) Flexible cable, A55 noise downconverter J4 to A7 noise receiver board P2

Refer to **Figure 12** for this part of this step of the procedure. Although only Option 219 is shown in the illustration, Option 224 is similar in appearance. New parts are listed in **Table 1 on page 8**.

4. The analyzer should be positioned on its left side (fans facing upwards) as shown.
5. Connect semirigid cables W141 and W143 as indicated. Torque connectors to 10 in-lbs.
6. Connect flexible cable W142 as indicated.
7. Go back and torque the connectors on the other ends of W141 and W143 to 10 in-lbs.

Figure 12 New Test Set Cable Installation, Part 2

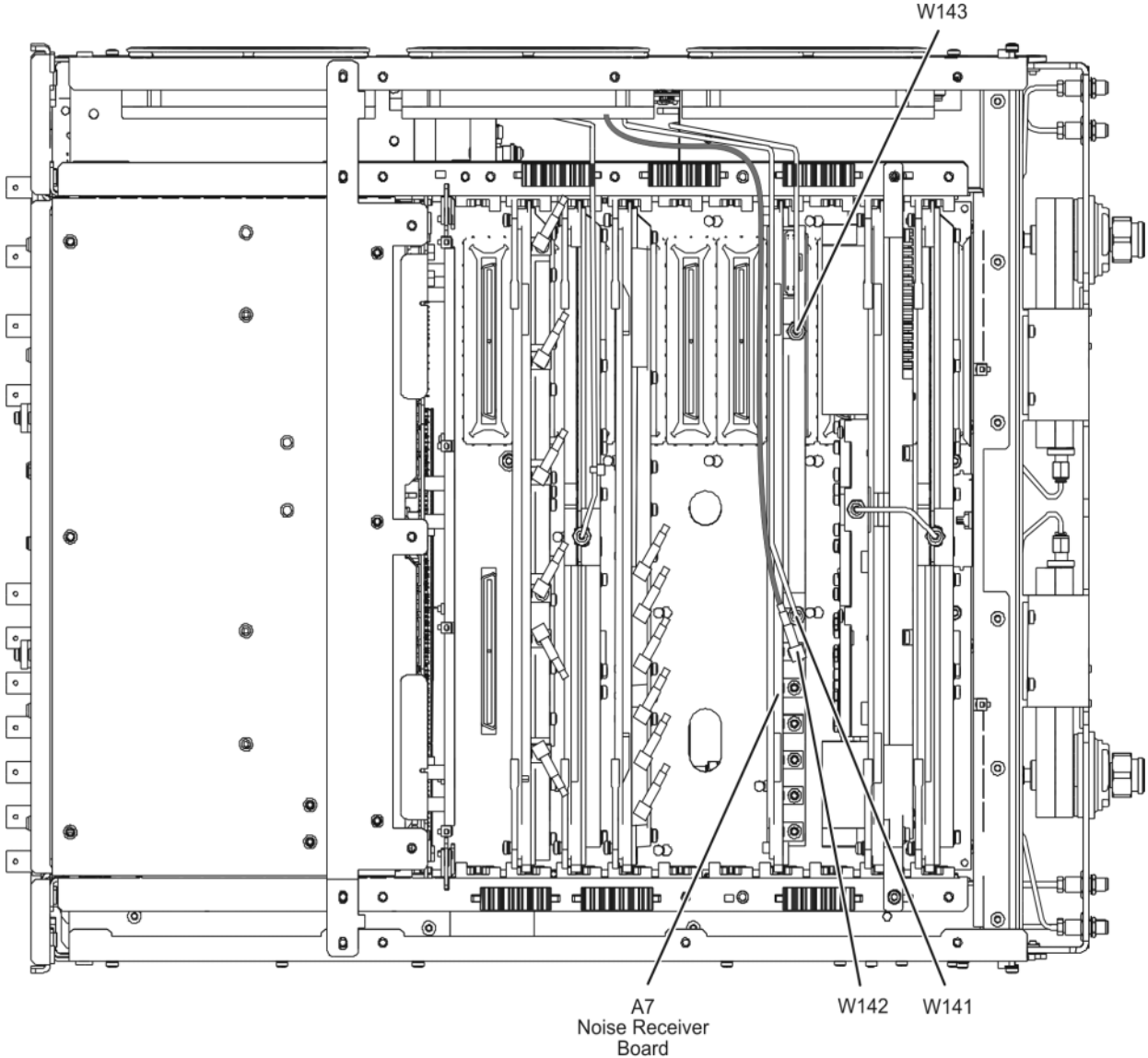

n5242_009_09

Step 16. Replace the A16 Power Supply (If Necessary)

Refer to **Figure 13** for this step of the procedure. The analyzer model shown in the illustration is for reference only and may not be the same as your analyzer. New parts are listed in **Table 1 on page 8**.

1. Check the part number of the power supply currently installed in your analyzer. The location of the part number is indicated in the illustration. If the correct power supply is installed, you need not replace it.
 - a. The part number should be as shown in **Table 1 on page 8**.
 - b. If the part number IS as shown, proceed to **“Step 17. Replace the Lower Front Panel Overlay”**.
 - c. If the part number IS NOT as show, continue with this step.
2. Remove the three flat head screws (item \neg) from the power supply bracket.
3. Remove the seven pan head screws (item \acute{A}) from the power supply rear panel.
4. Slide the A16 power supply assembly out the rear of the analyzer.
5. Slide the new A16 power supply assembly into position in the analyzer.
6. Reinstall the seven pan head screws (item \acute{A}) in the power supply rear panel.
7. Reinstall the three flat head screws (item \neg) in the power supply bracket.

Figure 13 Power Supply Replacement

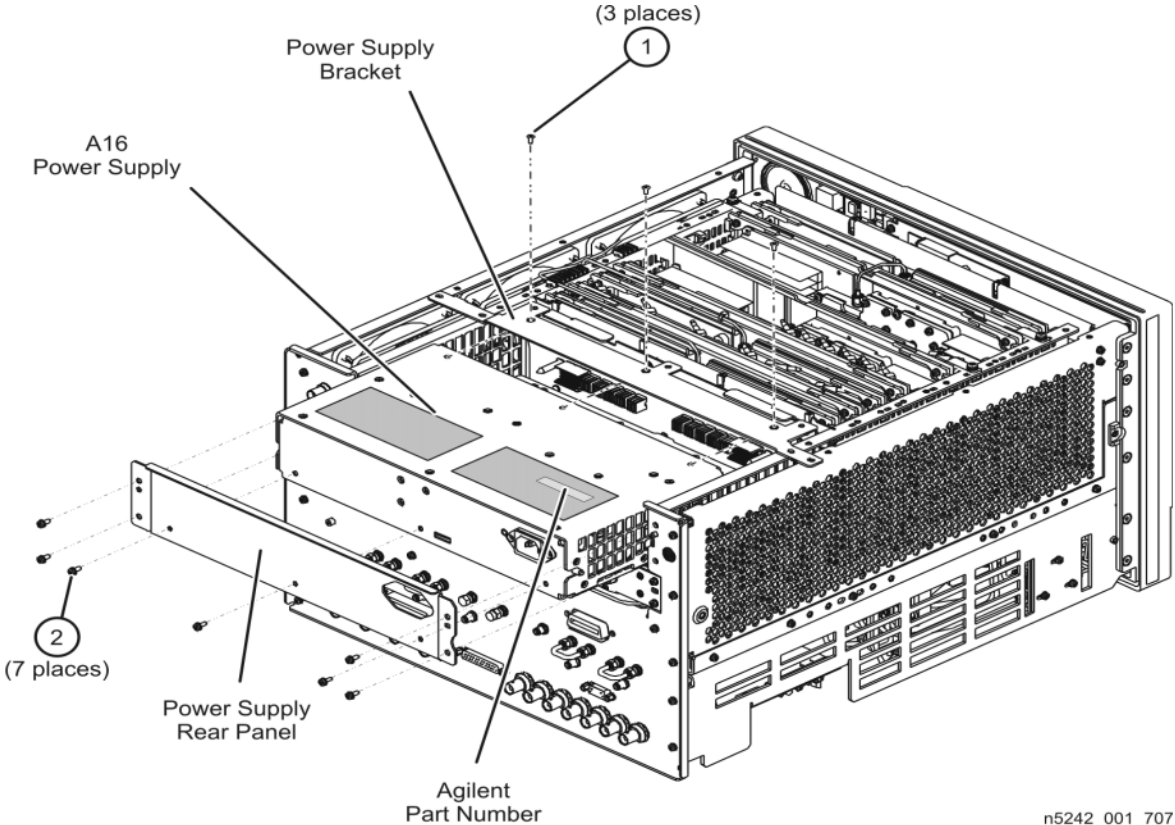

n5242_001_707

Step 17. Replace the Lower Front Panel Overlay

Refer to **Figure 14** for this step of the procedure. New parts are listed in **Table 1 on page 8**.

1. From the back side of the front panel, use a blunt object in the cutouts in the lower front dress panel to push on the old overlay (item **⌘**) and separate it from the front dress panel.
2. From the front side of the front panel, pull off the overlay completely and discard it.
3. Remove any adhesive remaining on the front panel.
4. Remove the protective backing from the new front panel overlay (item **Á**).
NOTE: There are two front panel overlays included in the upgrade kit; make sure you choose the correct one for your analyzer's model/option combination. Refer to **Table 1 on page 8**.
5. Starting from either side, loosely place the overlay in the recess on the lower front panel, ensuring that it fits tightly against the edges of the recess.
6. Once the overlay is in place, press it firmly onto the frame to secure it.

Figure 14 Lower Front panel Overlay Replacement

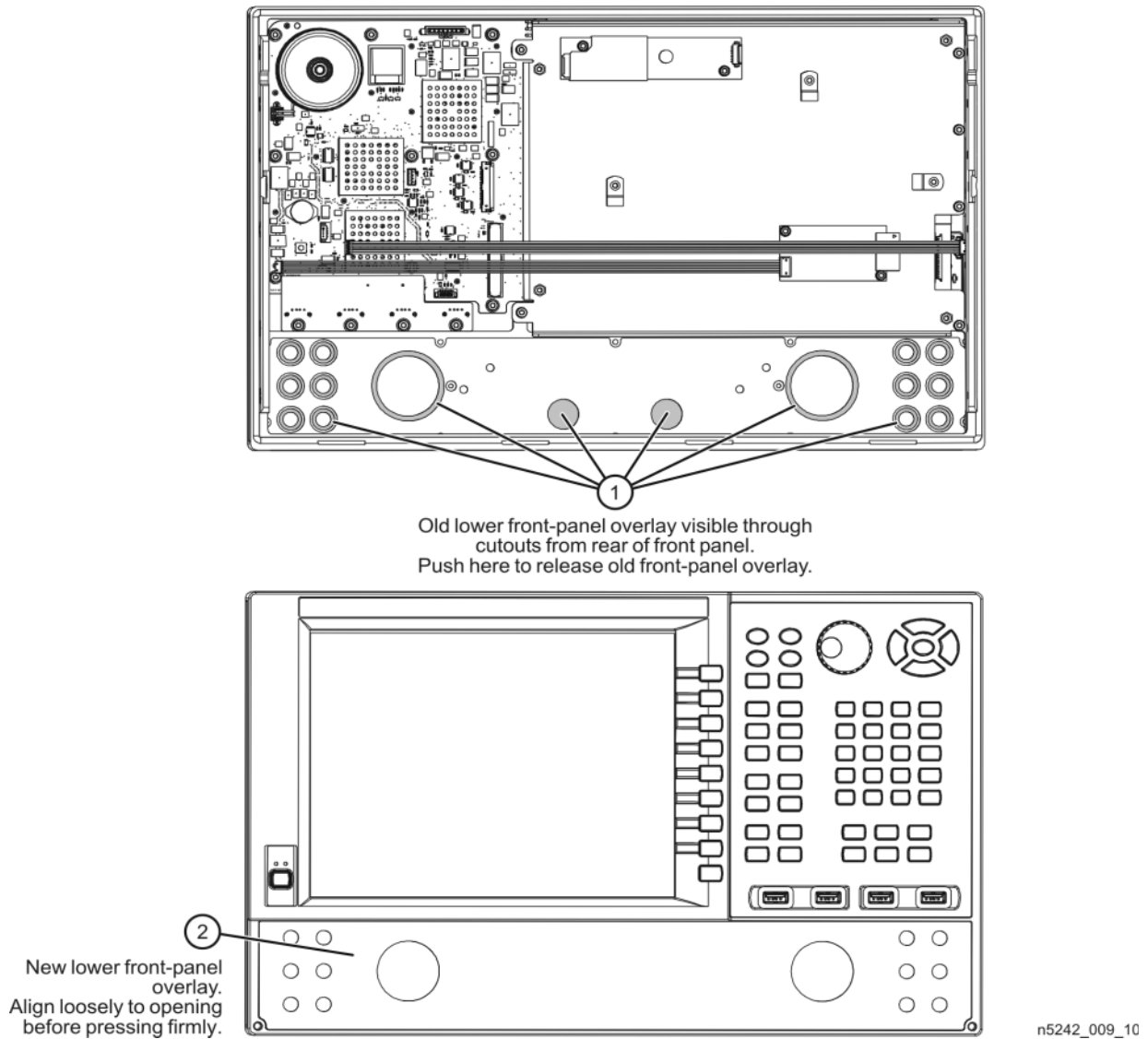

Step 18.Reinstall the Front Panel Assembly and Front Panel Jumpers

CAUTION

Before installing the front panel assembly onto the analyzer, lift and support the front of the analyzer chassis.

Refer to [Figure 15](#) for this step of the procedure. New parts are listed in [Table 1 on page 8](#).

1. Make sure all of the hex nuts on the front-panel cable connectors have been tightened using a 5/16-in torque wrench set to 21-in lbs.
2. Reconnect the ribbon cable (item [®]) to the A1 front panel interface board.

3. Slide the front panel over the front-panel connectors.
4. With a T-10 TORX driver, reinstall the 12 screws (item \hat{A}) in the sides of the frame.
5. Reinstall the semirigid jumpers (item \neg) on the front panel, and tighten each of the connectors to 10-in lbs.

Figure 15 Front Panel Assembly Reinstallation

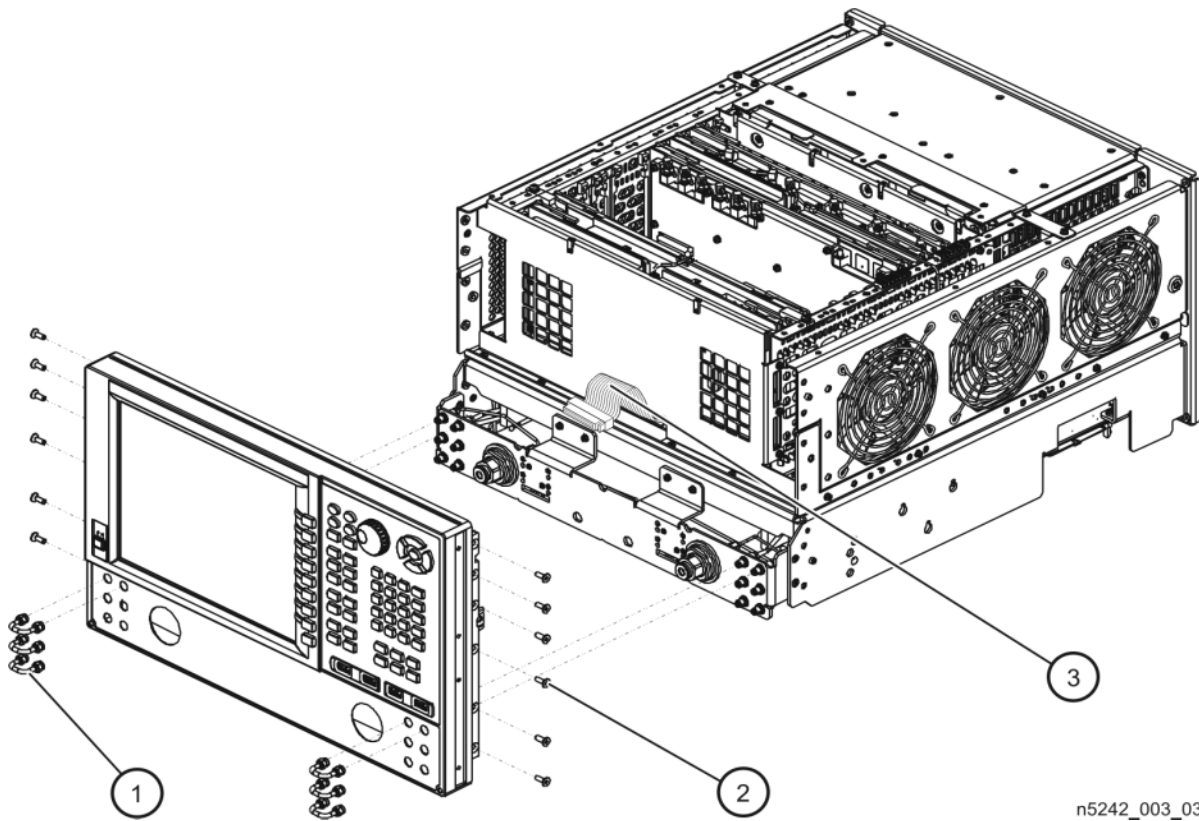

n5242_003_03

Step 19. Position the Cables and Wires to Prevent Pinching

On the top side of the PNA, carefully position the grey flex cables so they can't be pinched between the covers and the rails.

On the bottom side of the PNA, carefully fold or push down the ribbon cables and wires so they can't be pinched between the hardware and the outer cover. Ribbon cables and wires must never be positioned on top of hardware.

Step 20. Reinstall the Inner Cover

Refer to **Figure 16** for this step of the procedure.

1. Position the inner cover on the analyzer.
2. With a T-10 TORX driver, install the 12 pan head screws (item \neg).

3. With a T-10 TORX driver, install the 9 flat head screws (item Á).

Figure 16 Inner Cover Reinstallation

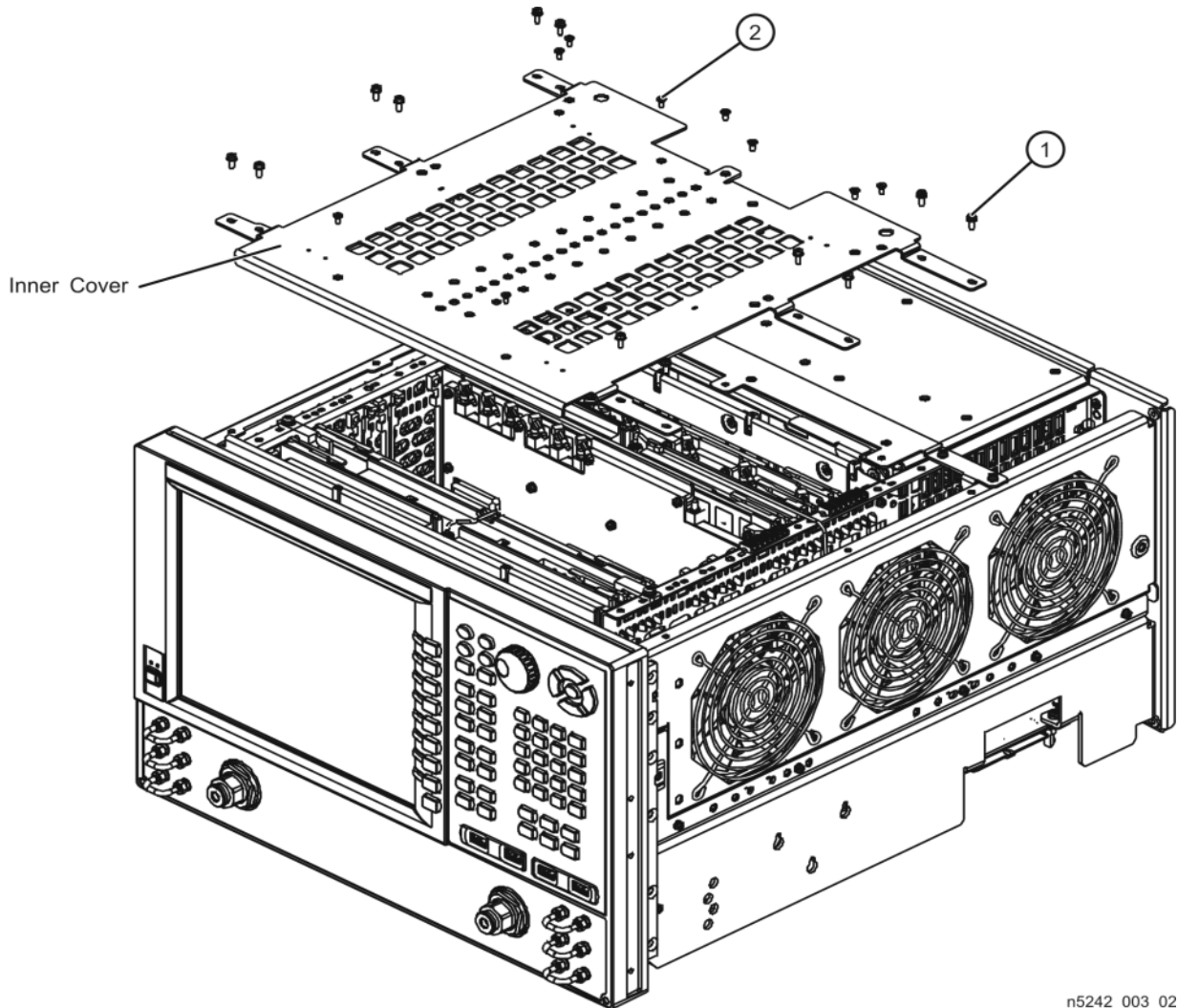

n5242_003_02

Step 21. Reinstall the Outer Cover

CAUTION

This procedure is best performed with the analyzer resting on its front handles in the vertical position. *Do not place the analyzer on its front panel without the handles.* This will damage the front panel assemblies.

Refer to [Figure 17](#) for this step of the procedure.

1. Slide the outer cover over the analyzer frame.
2. Install the four rear panel feet (item °) by installing the center screws (item ±) with a T-20 TORX driver,.

3. Install the four bottom feet (item ①) onto the bottom of the outer cover then install the foot locks (item ②).
4. Install the strap handles (item ③) by tightening the screws (item ④) on both ends of each strap handle with a T-20 TORX driver.

Figure 17 Outer Cover Reinstallation

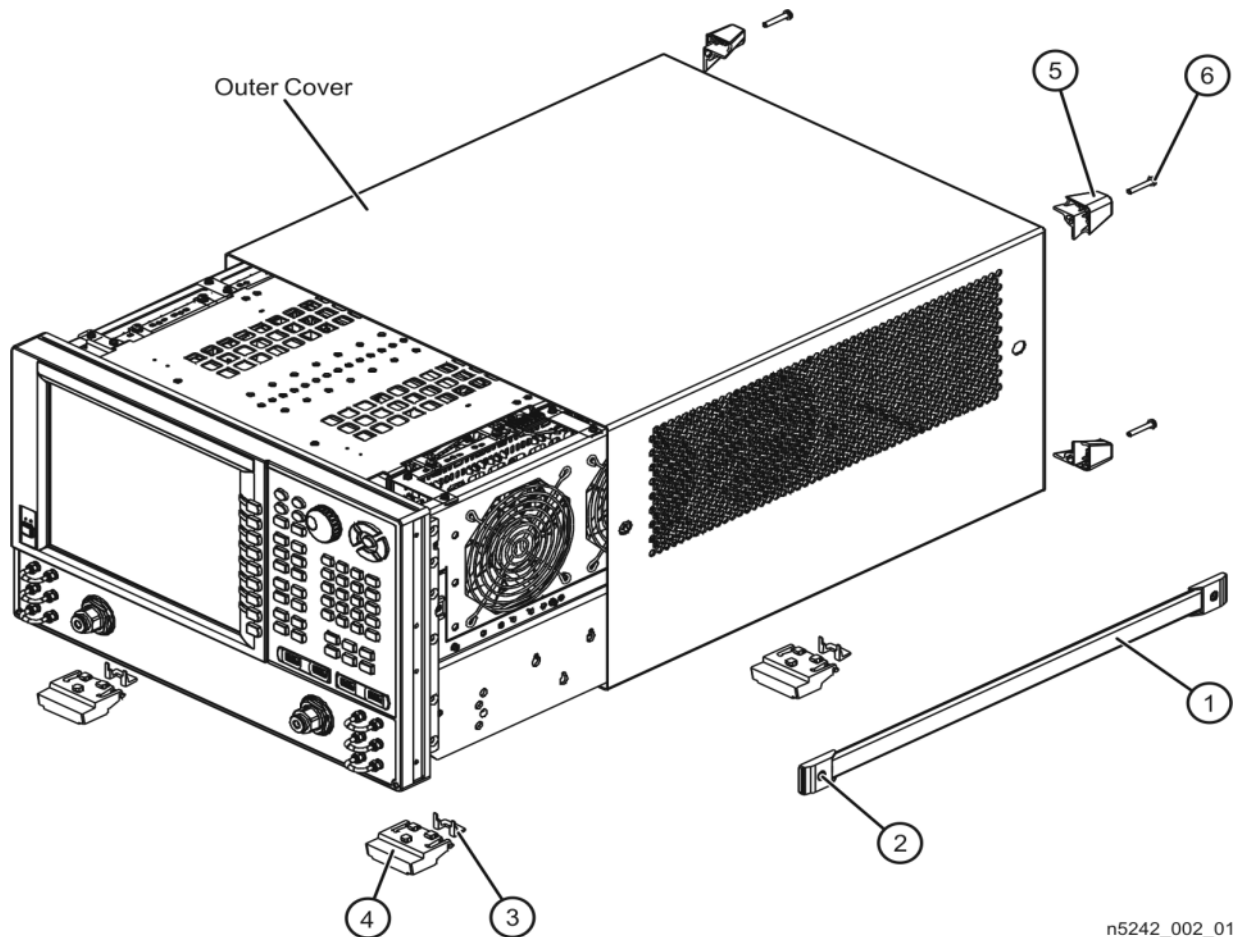

n5242_002_01

Step 22. Enable Option 029

Procedure Requirements

- The analyzer must be powered up and operating to perform this procedure.
- The Network Analyzer program must be running.
- A keyboard must be connected to the network analyzer.

Option Enable Procedure

1. To start the option enable utility, press UTILITY **System**, then **Service**, then **Option Enable**. An option enable dialog box will appear.

2. Click the arrow in the **Select Desired Option** box. A list of available options will appear.
3. In the **Select Desired Option** list, click **029 - Full Noise Measurements**.
4. Using the keyboard, enter the license key in the box provided. The license key is printed on the license message you received from Keysight. Enter this key *exactly* as it is printed on the message.
5. Click **Enable**.
6. Click **Yes** in answer to the displayed question in the **Restart Analyzer?** box.
7. When the installation is complete, click **Exit**.

Option Verification Procedure

Once the analyzer has restarted and the Network Analyzer program is again running:

1. On the toolbar at the top of the PNA display screen, click **Help**.
2. On the drop-down list, click **About Network Analyzer**.
3. In the About Network Analyzer window, under **Options**, verify that “029” is listed.
4. Click **OK**.

NOTE

If Option 224 has not been enabled, perform the "[Option Enable Procedure](#)" again. If the option is still not enabled, contact Keysight Technologies. Refer to "[Getting Assistance from Keysight](#)" on page 4.

Step 23. Verify Option 028 is Not Installed

Procedure Requirements

- The analyzer must be powered up and operating to perform this procedure.
- The Network Analyzer program must be running.
- A keyboard and mouse must be connected to the network analyzer.

Verify Option 028 is Not Installed

- On the toolbar at the top of the PNA display screen, click **Help**.
- On the drop-down list, click **About Network Analyzer**.
- In the About Network Analyzer window, under **Options**, verify that “028” is not listed.
 - If it is listed, continue with the instructions in this step to remove Option 028.
 - If it is not listed, skip the remainder of this step and go to the next one.

Option 028 Removal Procedure

1. To start the option enable utility, press UTILITY **System**, then **Service**, then **Option Enable**. An option enable dialog box will appear.
2. Click the arrow in the **Select Desired Option** box. A list of available options will appear.
3. In the **Select Desired Option** list, click **028**.
4. Click **Remove**.
5. Click **OK** to confirm that you want to remove the license for the selected option.
6. Click **Yes** in answer to the displayed question in the Restart Analyzer? box.

Step 24. Perform Post-Upgrade Adjustments and Calibration

Adjustments

The following adjustments must be made due to the hardware changes of the analyzer.

- Default EE adjustment - select the LO Drive-NF adjustment and either adjust or initialize the values.
- Source adjustment
- Receiver adjustment
- Noise figure adjustment

These adjustments are described in the PNA Service Guide and in the PNA on-line HELP. A list of equipment required to perform these adjustments is also found in the service guide.

To view this service guide information, click the Chapter 3 bookmark “Tests and Adjustments” in the PDF Service Guide¹.

After the specified adjustments have been performed, the analyzer should operate and phase lock over its entire frequency range.

Operator’s Check

Perform the Operator’s Check to check the basic functionality of the analyzer. For instructions, click the Chapter 3 bookmark “Tests and Adjustments” in the PDF Service Guide¹.

If you experience difficulty with the basic functioning of the analyzer, contact Keysight. Refer to [“Contacting Keysight” on page 4](#).

Calibration

Although the analyzer functions, its performance relative to its specifications

1. See [“Downloading the Online PNA Service Guide” on page 6](#).

has not been verified. It is recommended that a full instrument calibration be performed using the analyzer's internal performance test software. To view information on the performance test software, click the Chapter 3 bookmark "Tests and Adjustments" in the PDF Service Guide¹.

Step 25. Prepare the PNA for the User

1. If necessary, reinstall front jumper cables.
2. If necessary, reinstall the cable guards, pushing them over the front jumper cables until the cushioning material touches the front panel of the PNA.
3. Install the dust caps on the test ports.
4. Clean the analyzer, as needed, using a damp cloth.

Installation Procedure for the Upgrade



This information is subject to change without notice.

© Keysight Technologies 2007-2016

Edition 1, July 2016



N5242-90009

www.keysight.com